

**Bio 235****TAB. 1 – Diesel machine Assembly**

Pos.	Description	No.	Code
1	Road trailer 80 Km/H (TAB. 2)	1	001009
2	Hopper Assembly (TAB. 4)	1	001010
3	Engine & transmission Assembly (TAB.9)	1	001011
4	Engine cover Assembly (TAB. 12)	1	001012
5	Transmission shaft Assembly (TAB. 13)	1	001013
6	Washer $\varnothing$ 10x20	16	900028
7	Self lock nut M10	6	900030
8	Screw TE M10x35	2	900442
9	Chipper box Assembly (TAB. 14)	1	001014
10	Washer $\varnothing$ 12x24	12	900344
11	Self lock nut M12	8	900362
12	Washer $\varnothing$ 8x16	8	900034
13	Self lock nut M8	2	900027
14	Screw TE M8x30	2	900368
15	Screw TE M12x25	4	900450
16	Screw TE M10x25	4	900380
17	Screw TE M12x30	4	900373
18	Screw TE M8x16	4	900401

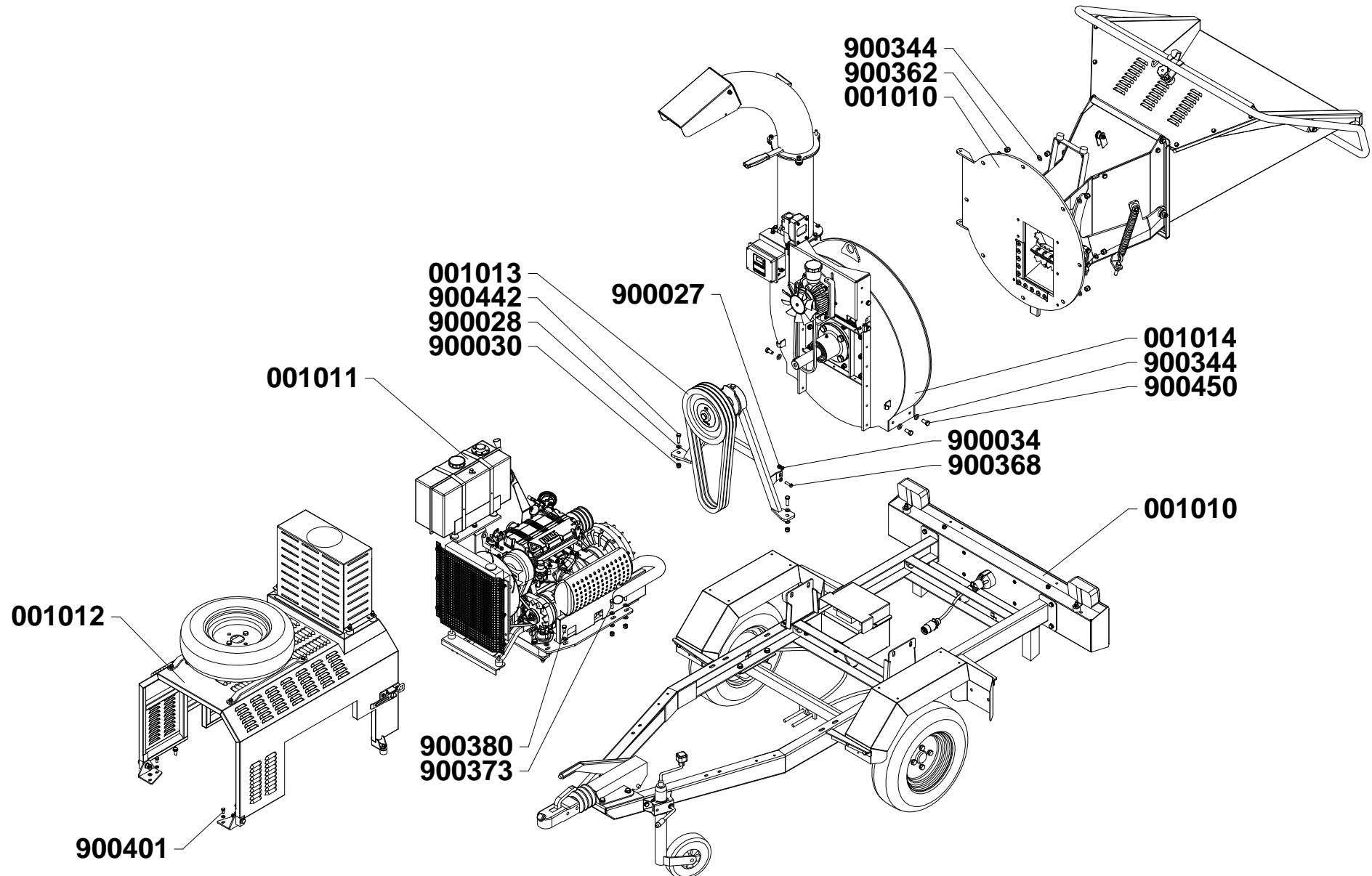

**Bio 235****TAB. 2 – Road trailer 80 Km/H**

Pos.	Description	No.	Code
1	Chassis	1	001033
2	Axle 850 Kg	1	900245
3	Wheel 145/80 R13	2	900246
4	Towing coupler	1	900243
5	Jockey wheel support	1	900583
6	Jockey wheel ø48	1	900244
7	Washer ø12x24	12	900344
8	Screw TE M12x25	4	900450
9	Washer ø10x20	36	900028
10	Self lock nut M10	16	900030
11	Screw TE M10x25	16	900380
12	Self lock nut M12	4	900362
13	Screw TE M12x35	4	900407
14	Screw TE M12 for wheels	8	900709
15	Mudguard	2	000282
16	Machine support	2	B19008011
17	Lighting bar Assembly (TAB. 3)	1	000545
18	Battery 50 Ah	1	900714
19	Battery box	1	001031
20	Battery cover	1	001032
21	Screw TE M10x30	4	900373
22	Wiring cable Assembly	1	000290
23	Brake cable	2	900710

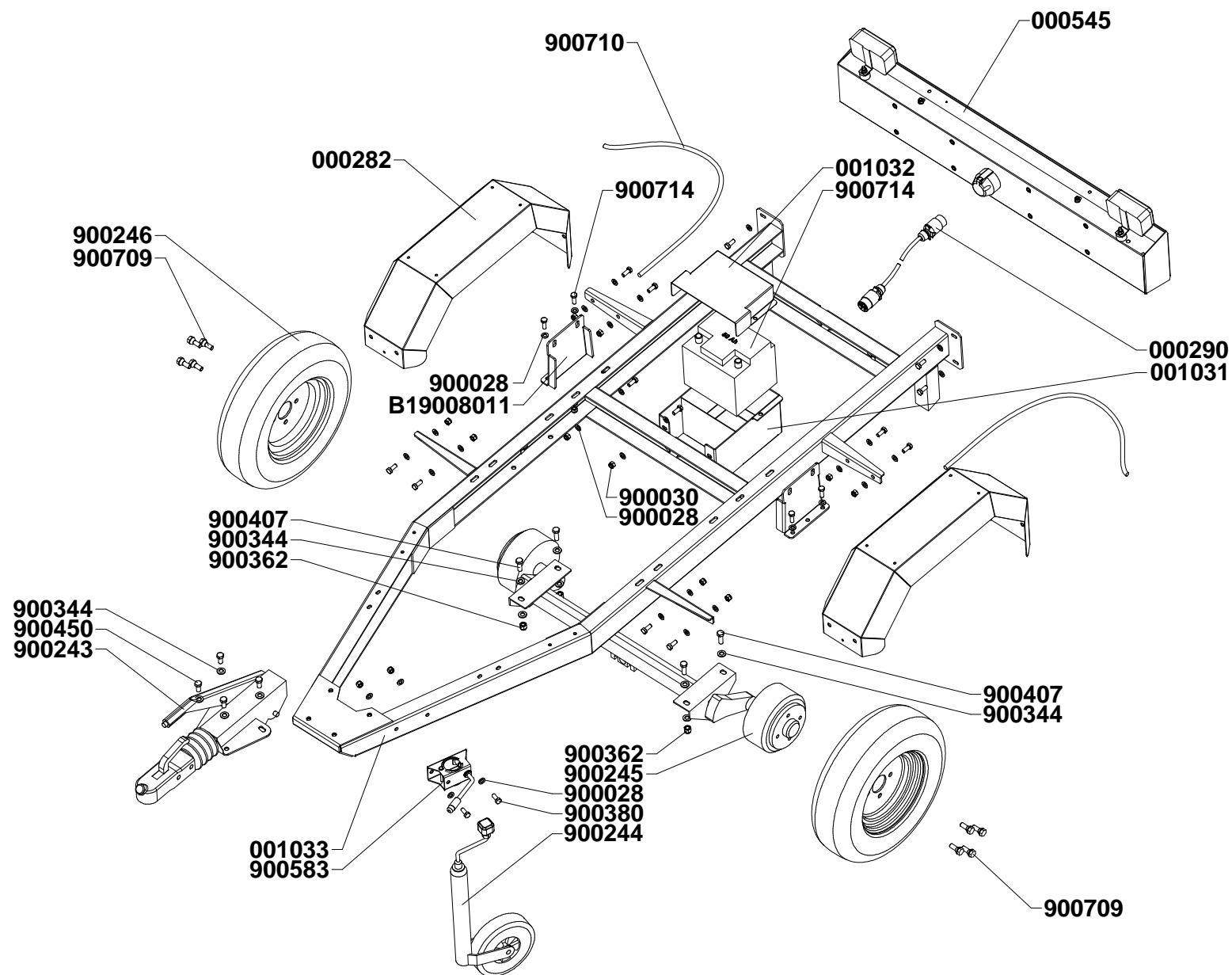

**Bio 235****TAB. 3 – Lighting bar Assembly**

Pos.	Description	No.	Code
1	Bar casing	1	000963
2	Bar lighting	1	000285
3	Rear reflector	2	900247
4	Lighting box	2	900250
5	Light plate	2	900691
6	Washer ø8x16	4	900034
7	Screw TE M8x25	4	900333
8	Electrical outlet	1	900688
9	Rubber foot ø40x20 2x M8 M	2	900645
10	Light reverse	1	900689
11	Light fog	1	900690

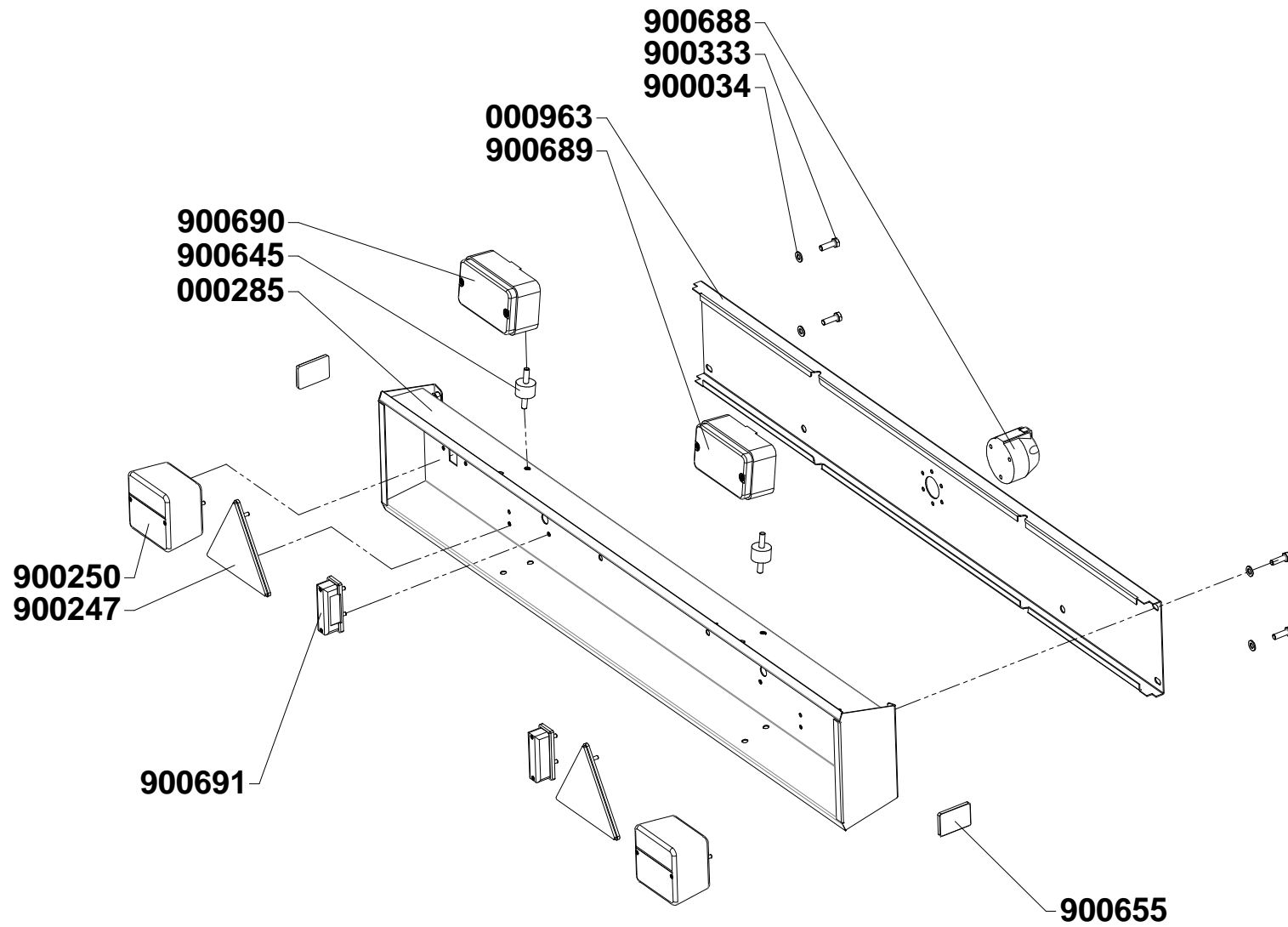

**Bio 235****TAB. 4 – Hopper & feed roller Assembly**

Pos.	Description	No.	Code
1	Hopper Assembly (TAB. 5)	1	001015
2	Feed roller box Assembly (TAB. 6)	1	001016
3	Lock	2	B19001033
4	Screw TE M10x40	2	900363
5	Nut M8	2	900720
6	Screw TE M8x35	1	900335
7	Screw TE M8x65	1	900474
8	Self lock nut M8	1	900027
9	Spring	1	900717
10	Flange	1	B23001028
11	Counter blade	2	B19010027
12	Washer ø10x20	16	900028
13	Screw TE M10x20	6	900242
14	Self lock nut M10	10	900030
15	Screw TSPEI M10x30	10	900473

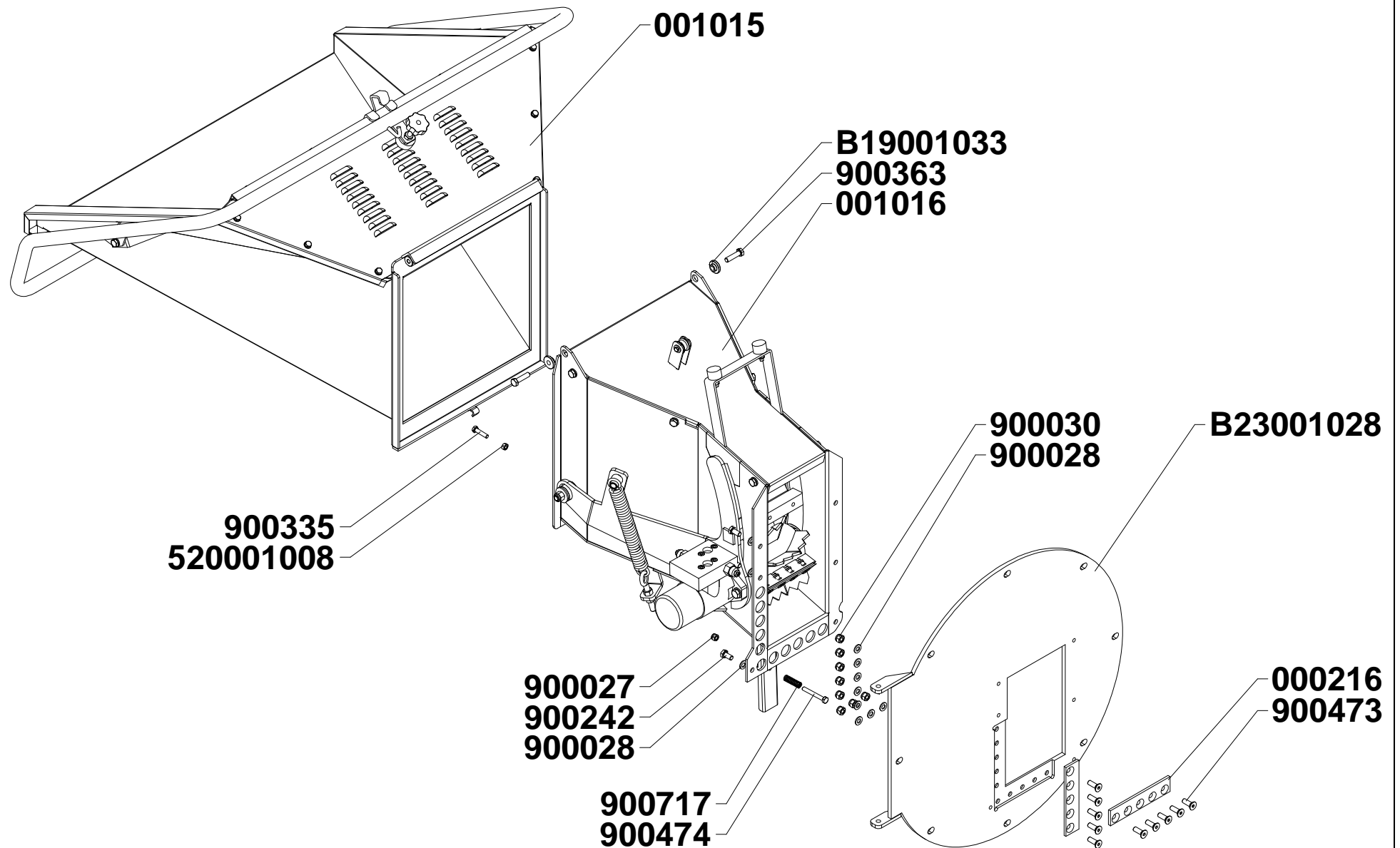

**Bio 235****TAB. 5 – Hopper Assembly**

Pos.	Description	No.	Code
1	Hopper	1	001017
2	Hopper cover	1	001018
3	Plate	1	001019
4	Handle	1	B23002024
5	Washer $\varnothing$ 10x20	4	900028
6	Self lock nut M10	2	900030
7	Screw TE M10x30	2	900373
8	Washer $\varnothing$ 9x16	22	900034
9	Self lock nut M8	11	900027
10	Screw TE M8x25	5	900333
11	Screw TE M8x20	6	900378
12	Hook	1	001020
13	Elastic support $\varnothing$ 40x20 M8 F	1	B23002026
14	Knob 6E M10x60	1	900211
15	Nut M10	1	900705
16	Protection rubber	1	B23002028

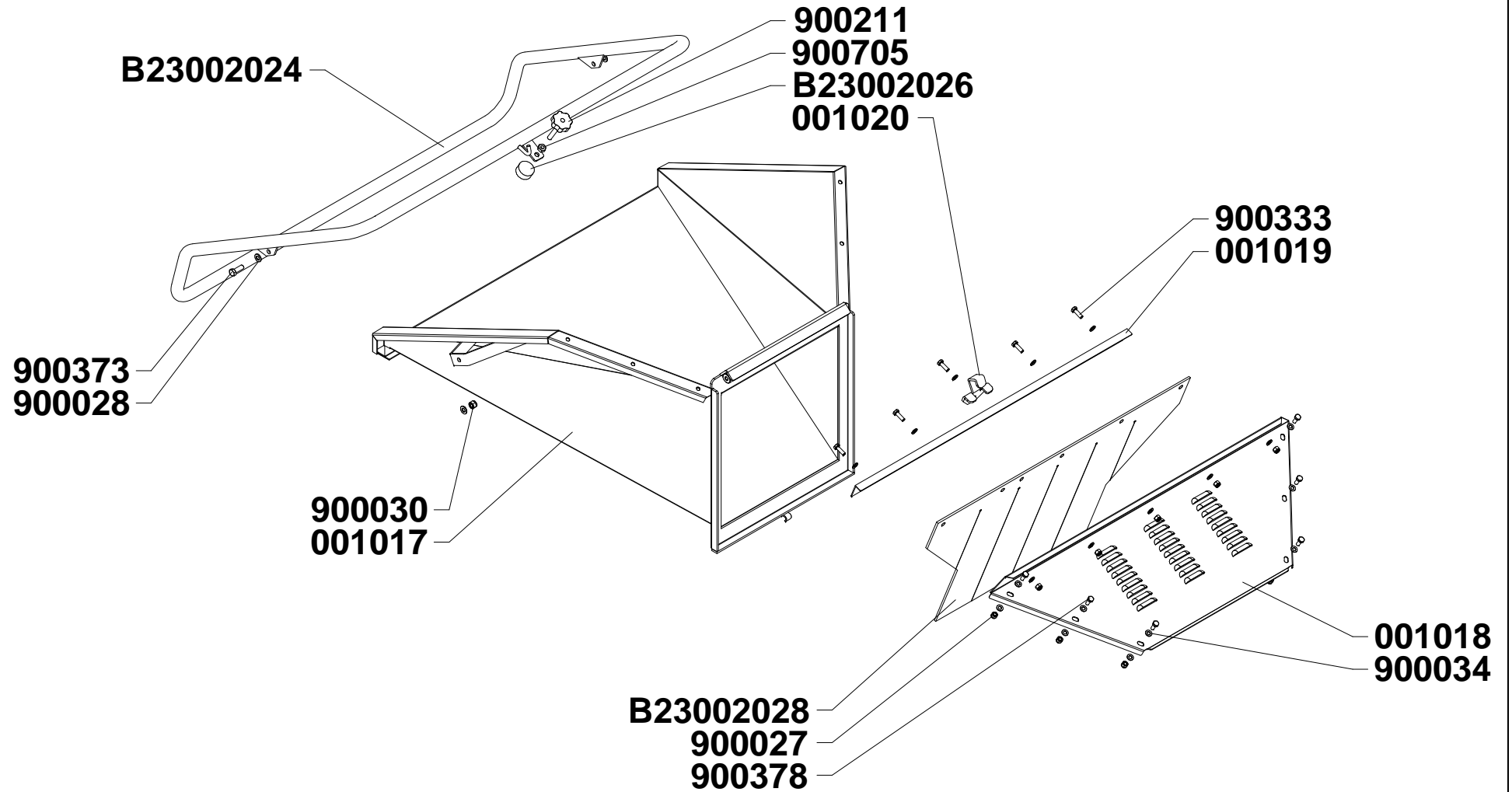

**Bio 235****TAB. 6 – Feed roller box Assembly**

Pos.	Description	No.	Code
1	Feed roller box	1	001021
2	Feed roller box cover	1	001022
3	Screw TB M12x55	2	900718
4	Bush	2	001023
5	Bush with collar ø20	2	900517
6	Washer ø12x36	2	900477
7	Self lock nut M12	2	900362
8	Feed roller and frame Assembly (TAB. 7)	1	001024
9	Washer ø10x20	6	900028
10	Screw TE M10x25	6	900380
11	Aluminium pulley	1	000987
12	Washer ø6x18	2	900046
13	Self lock nut M12	1	900041
14	Screw TE M6x40	1	900707
15	Elastic support ø40x20 M8 M	2	900036
16	Washer ø8x16	4	900034
17	Self lock nut M8	4	900027
18	Rod	2	B230020010
19	Spring	2	900469
20	Eyebolt M12	2	900435
21	Nut M12	4	520004012
22	Screw TE M10x40	2	900363
23	Switch lever	1	001025
24	Nut M10 (high)	2	900462
25	Nut M10 (low)	2	900377

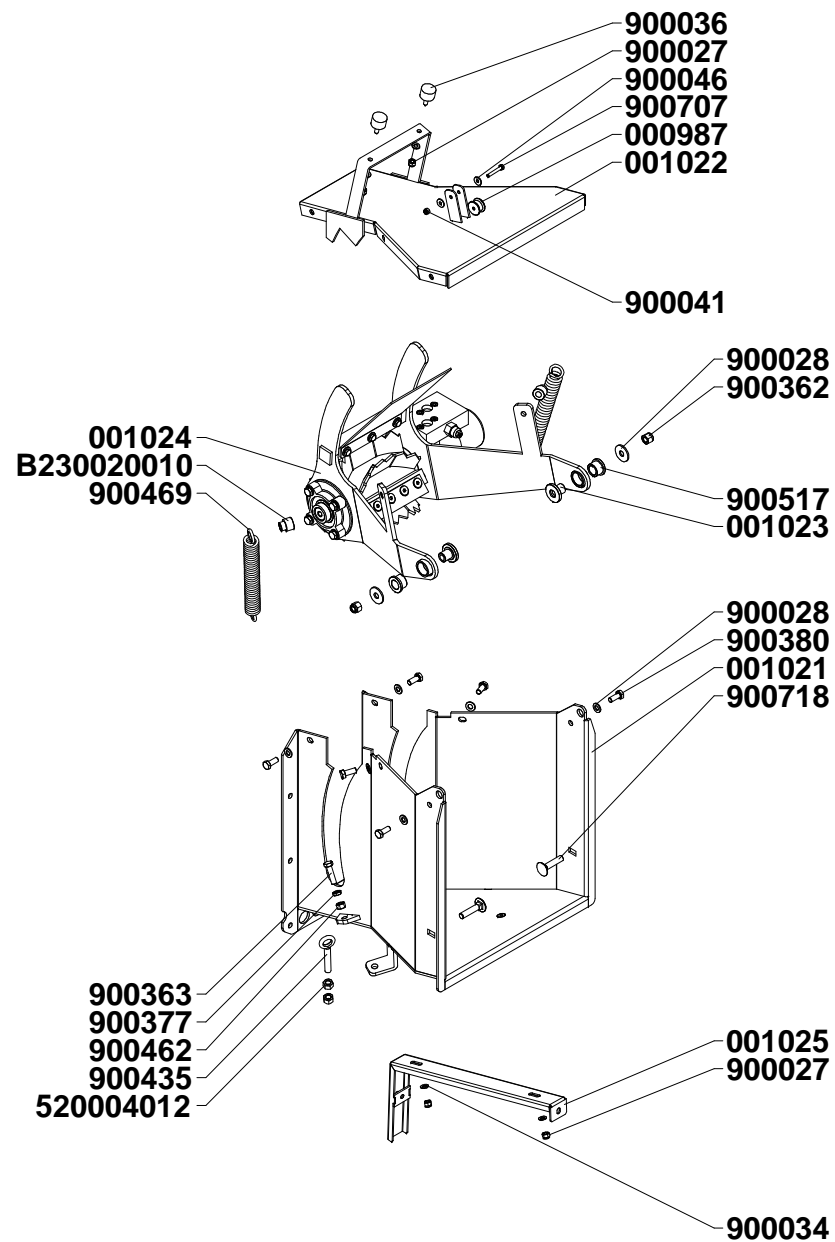

**Bio 235****TAB. 7 – Feed roller and frame**

Pos.	Description	No.	Code
1	Feed roller frame	1	001027
2	Feed roller cover	1	001028
3	Washer $\varnothing$ 10x20	7	900028
4	Screw TE M8x25	3	900333
5	Bush ring	2	001026
6	Bearing UCFC 206	1	900721
7	Screw TE M10x35	4	900442
8	Feed roller with blades (TAB. 8)	1	001029
9	Hydraulic motor OP 400	1	900270
10	Washer $\varnothing$ 12x24	2	900344
11	Screw TE M12x30	2	900308
12	Key 8x7x30	1	900376
13	Hydraulic valve	1	900269
14	Screw TCEI M8x40	4	900693

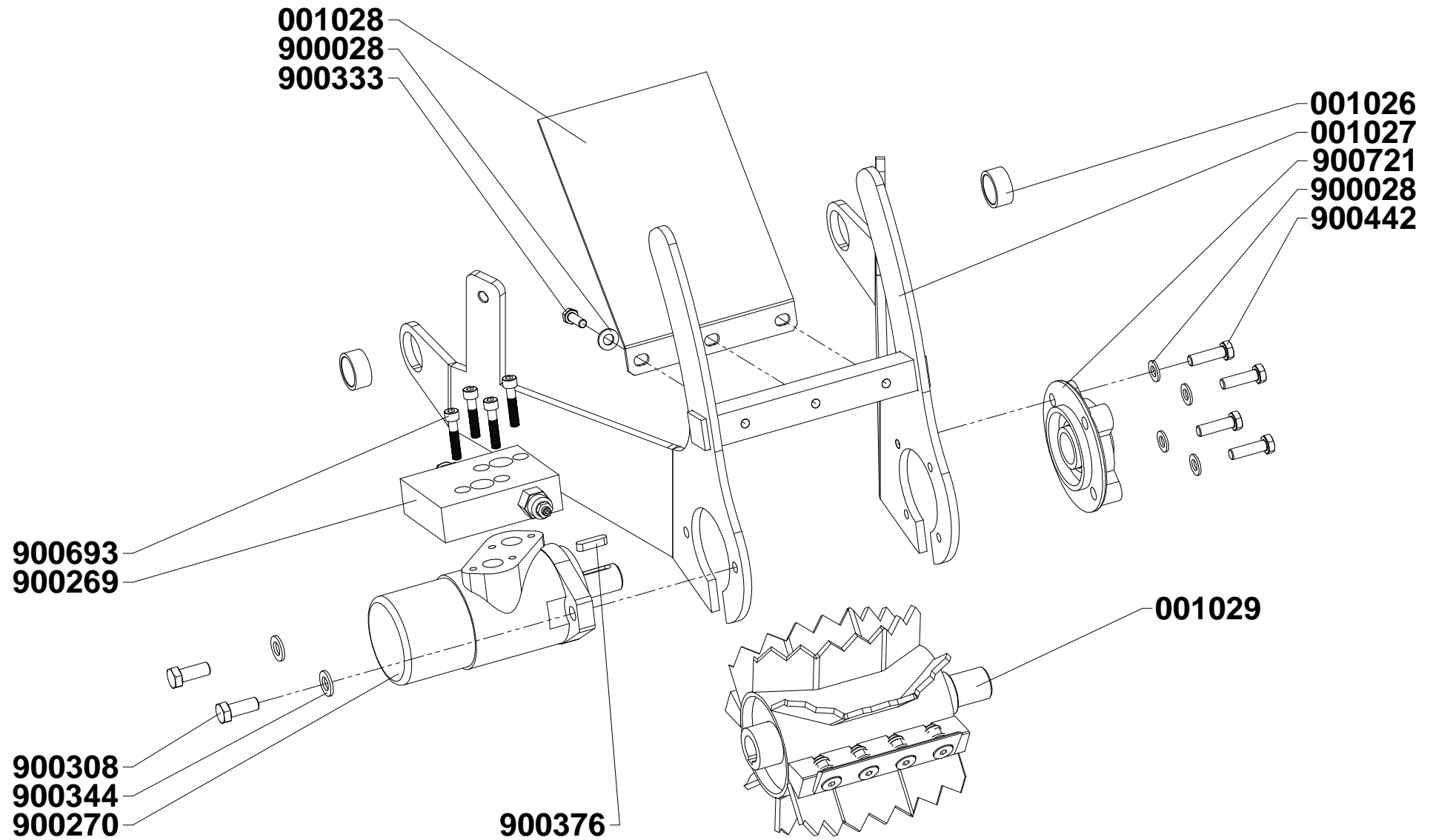

**Bio 235**

**TAB. 8 – Feed roller with blades**



Pos.	Description	No.	Code
1	Blade	2	000042
2	Washer ø10x20	8	900028
3	Self lock nut M10	8	900030
4	Screw TSPEI M10x30	8	900473
5	Feed roller Assembly	1	001030

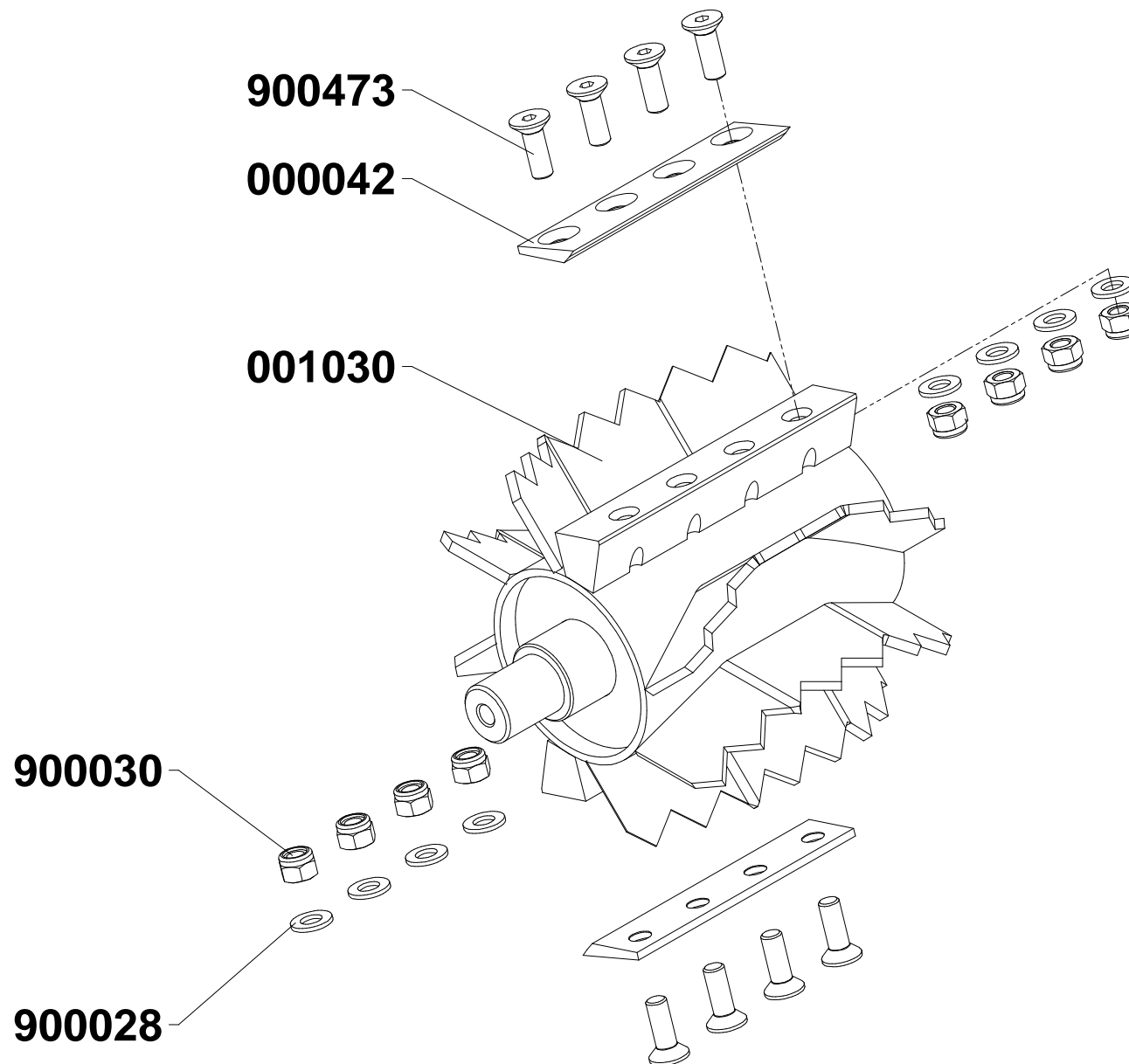

**Bio 235****TAB. 9 – Engine and transmission Assembly**

Pos.	Description	No.	Code
1	Front engine support	1	000313
2	Spacer	2	001034
3	Elastic support	4	900285
4	Left engine support	1	001035
5	Right engine support	1	001036
6	Washer ø12x24	9	900344
7	Screw TE M12x150	2	900209
8	Self lock nut M12	4	900362
9	Washer ø10x20	17	900028
10	Screw TE M10x20	9	900242
11	Cover	1	001037
12	Screw TSPEI M10x25	2	900225
13	Self lock nut M10	6	900030
14	Tank support	1	001038
15	Screw TSPEI M10x35	2	900224
16	Fuel tank Assembly (TAB. 10)	1	900725
17	Screw TE M10x35	2	900442
18	Accelerator lever	1	900151
19	Switch support	1	001039
20	Washer ø8x16	14	900034
21	Screw TE M8x16	1	900401
22	Safety switch	1	900219
23	Screw TCEI M5x35	2	900497
24	Washer ø5x10	2	900471
25	Self lock nut M5	2	900702
26	Coupling 9K	1	900726
27	Diesel engine 27 HP	1	900284
28	Radiator	1	900282
29	Radiator protection	1	001040
30	Idler plate	1	001041
31	Engine support	2	001042
32	Muffler support	1	000309
33	Screw TE M12x110	2	900722
34	Muffler	1	900286
35	Screw TE M8x25	6	900333
36	Idler Assembly (TAB. 11)	1	001043
37	Accelerator support	1	001044
38	High nut M12	2	900451

Pos.	Description	No.	Code
39	Screw TE M8x20	1	900378
40	Self lock nut M8	4	900027
41	Washer ø6x18	12	900046
42	Self lock nut M6	6	900041
43	Screw TE M6x20	6	900395
44	Screw TE M12x30	9	900308
45	Coupling washer	1	001045
46	Screw TE M12x180	1	900723
47	Radiator support	1	900283
48	High nut M8	2	900274
49	Rubber foot ø40x20 2 M8 M	2	900281
50	Muffler collector	1	000310

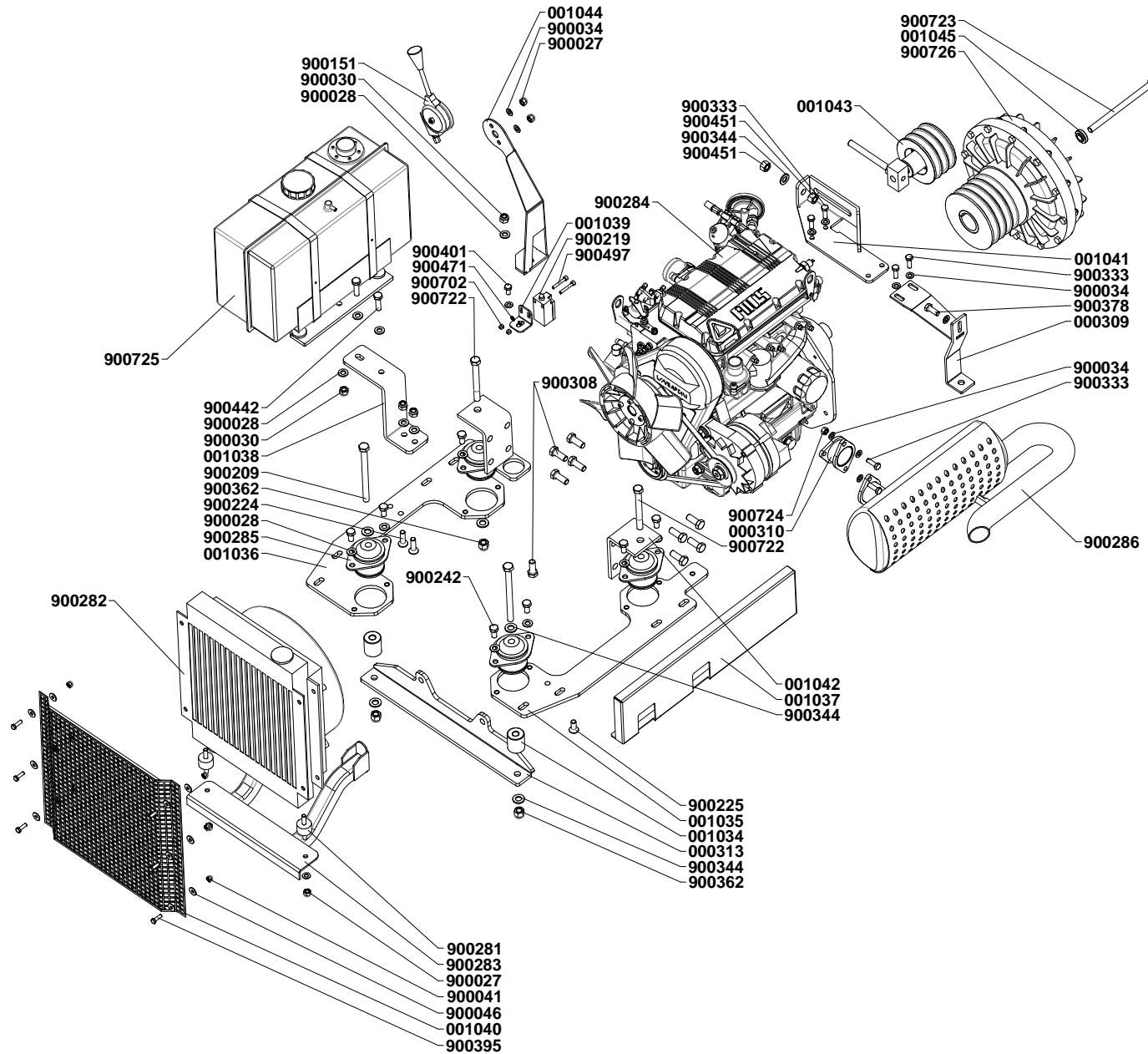

**Bio 235**

**TAB. 10 – Fuel tank Assembly**



Pos.	Description	No.	Code
1	Fuel Tank	1	900290
2	Bottom plate	1	900727
3	Plate	1	900293
4	Elastic support	4	900294
5	Washer ø8x16	4	900034
6	Nut M8	4	900720
7	Tank bracket	2	900728
8	Screw TCEI M5x35	2	900497

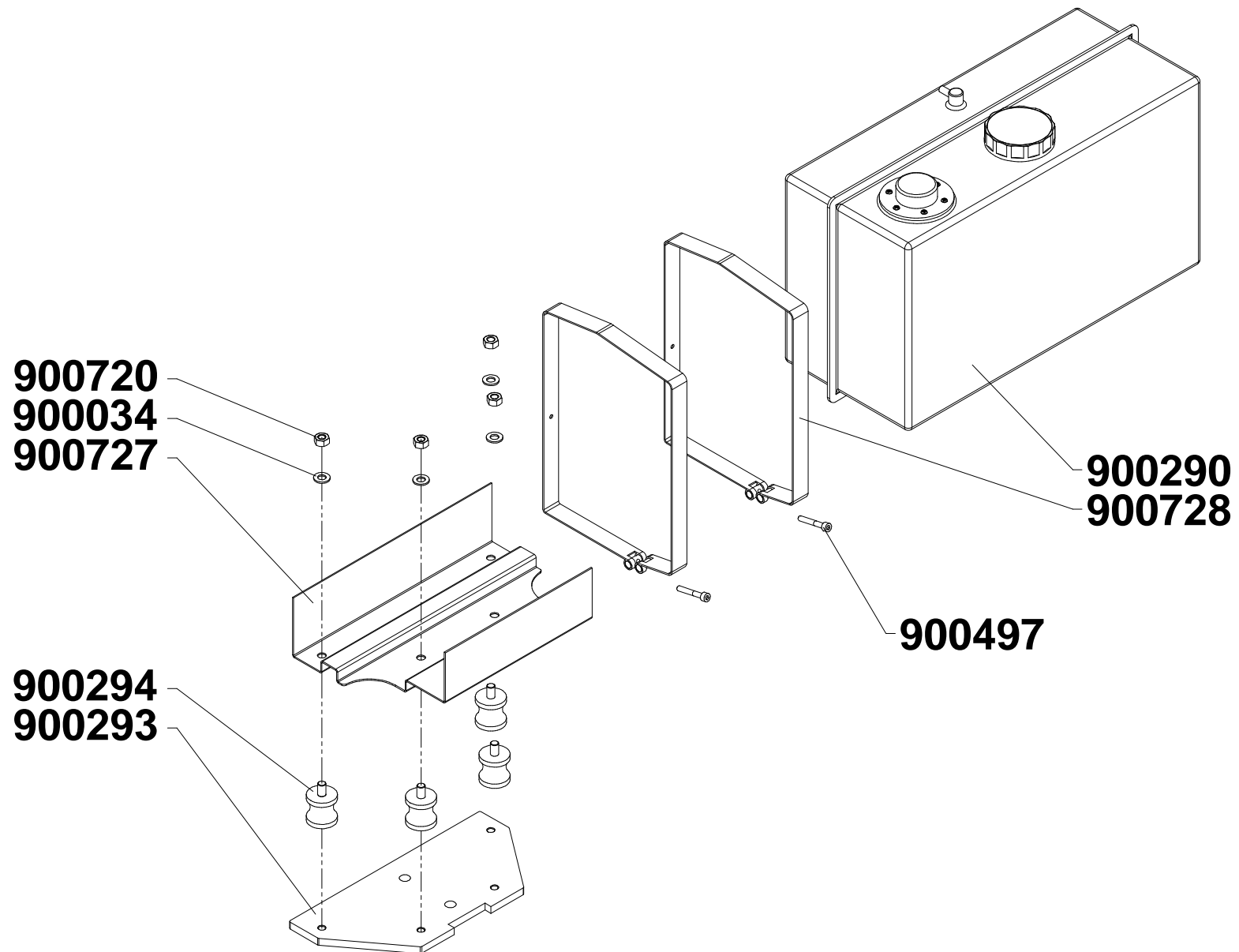

**Bio 235**

**TAB. 11 – Idler Assembly**



Pos.	Description	No.	Code
1	Rod	1	001047
2	Idler pulley 3 SPB 100	1	001046
3	Bearing 6206 2RS	1	900700
4	Seeger ring ø62	1	900729
5	Lock washer	1	001048
6	Lock	1	001049
7	Screw TE M16x100	1	900578
8	Rod M12	1	001050
9	High nut M12	1	900451

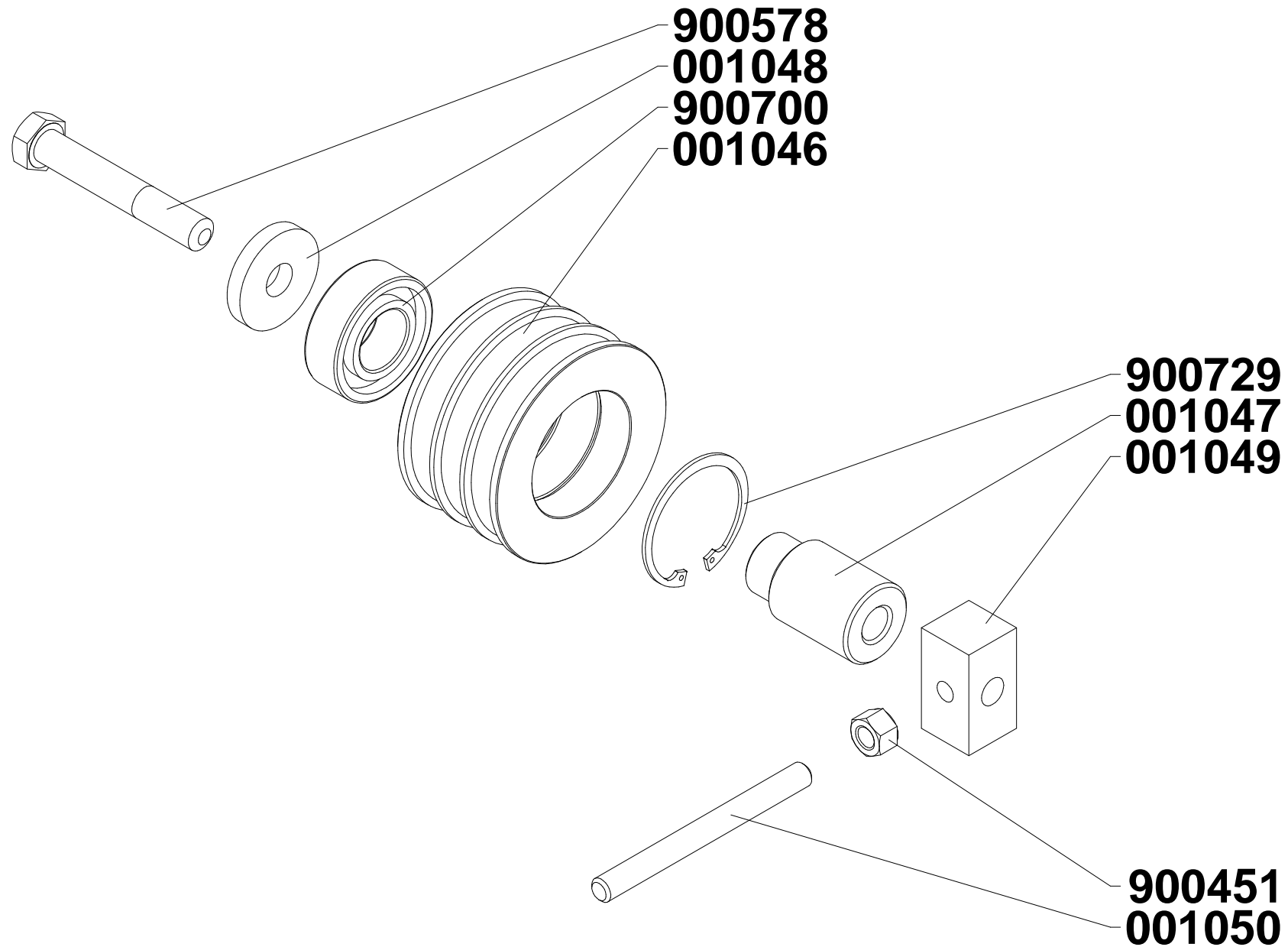

**Bio 235****TAB. 12 – Engine cover Assembly**

Pos.	Description	No.	Code
1	Engine cover	1	001051
2	Elastic support ø40x20 2 M8 M	4	900281
3	Pump cover	1	B23003015
4	Washer ø8x16	18	900034
5	Self lock nut M8	10	200027
6	Hook	2	900618
7	Screw TE M8x25	4	900333
8	Elastic support ø40x20 M8 M	2	900292
9	Left hinge	1	001052
10	Washer ø12x24	4	900344
11	Screw TE M12x60	2	900374
12	Self lock nut M12	2	900362
13	Right hinge	1	001053
14	Wheel bottom support	2	000288
15	Wheel support	1	000287
16	Screw TE M8x30	4	900368
17	Screw TE M10x30	2	900373
18	Washer ø10x20	2	900028
19	Self lock nut M10	2	900030
20	Wheel 145/80 R13	1	900246
21	Screw TE M12x25	2	900450

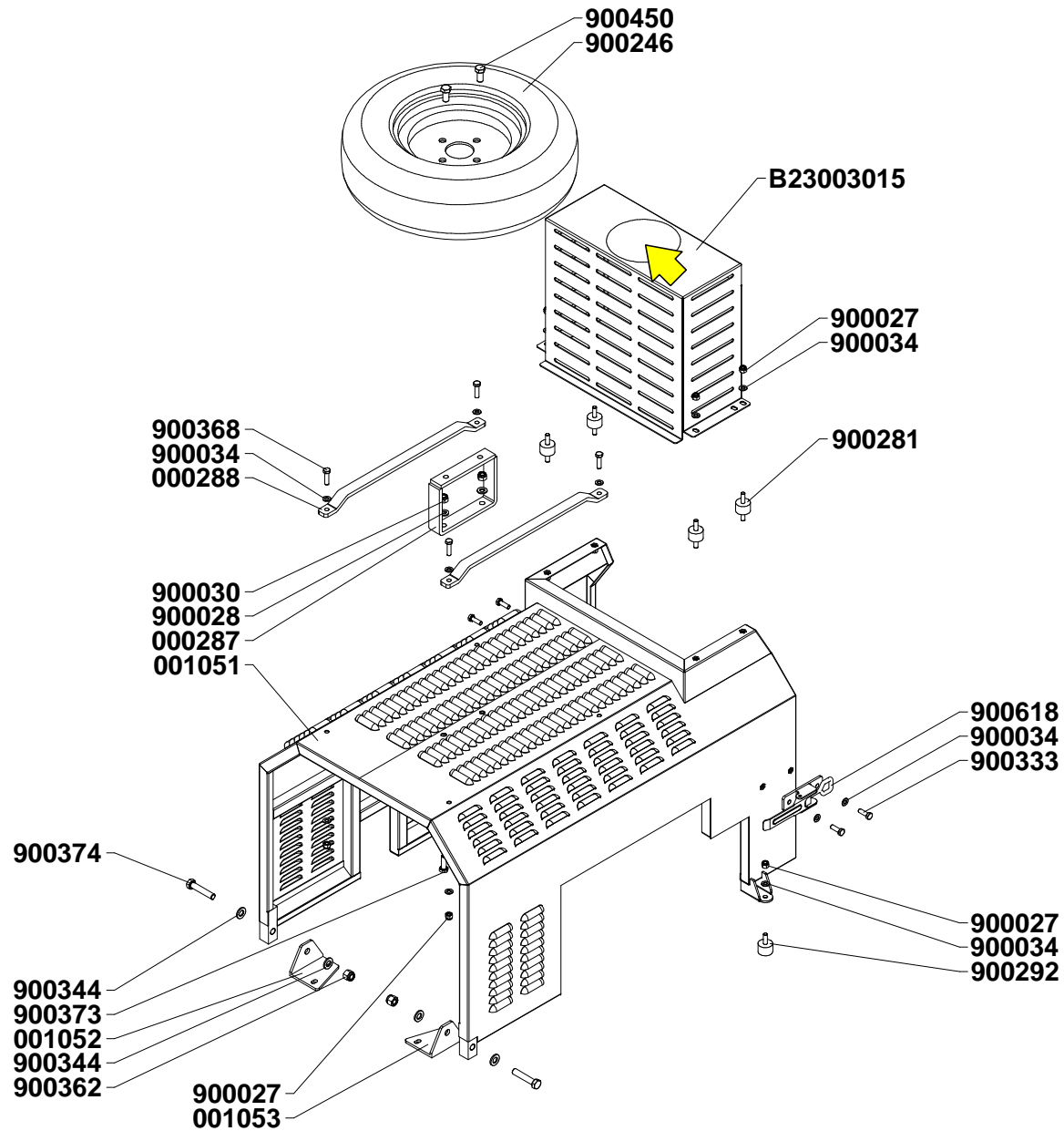

**Bio 235****TAB. 13 – Transmission shaft Assembly**

Pos.	Description	No.	Code
1	Transmission support	1	001055
2	Counter revs disk	1	000230
3	Spacer	1	001054
4	Bush 1610 ø42	1	900467
5	Pulley 1 SPA 118	1	900217
6	Bush 3020 ø42	1	900580
7	Pulley 3 SPA 250	1	900731
8	Lock washer ø50x15x8	1	900730
9	Belt B-53	3	001056
10	Screw TE M14x40	1	900417
11	Screw TE M12x30	1	900308

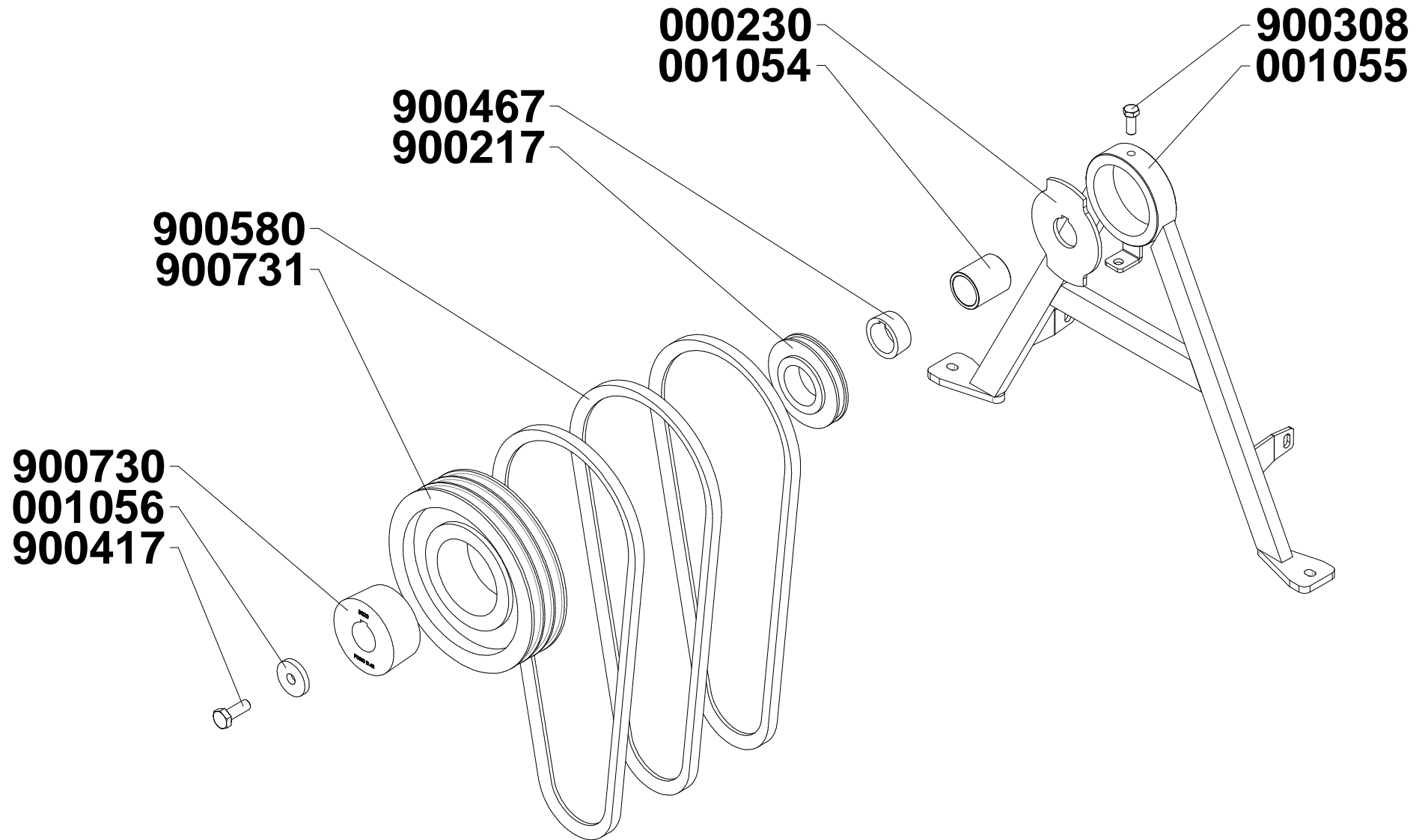

**Bio 235****TAB. 14 – Chipper box Assembly**

Pos.	Description	No.	Code
1	Chipper box	1	001058
2	Exhaust pipe Assembly (TAB. 15)	1	000524
3	Plate (transmission)	1	B19002026
4	Transmission flange Assembly (TAB. 16)	1	B19002025
5	Rotor Assembly (TAB. 17)	1	001059
6	Washer $\varnothing$ 14x28	4	900422
7	Screw TE M14x30	4	900441
8	Washer $\varnothing$ 10x20	18	900028
9	Self lock nut M10	10	900030
10	Pump support	1	B23003005
11	Pump Assembly (TAB. 18)	1	001057
12	Plate (pump)	2	000297
13	Screw TE M10x20	4	900242
14	Screw TE M10x60	4	900155
15	Belt SPA-36	1	B23004022
16	Elastic support $\varnothing$ 40x20 2 M8 M	2	900281
17	Washer $\varnothing$ 8x16	20	900034
18	Screw TE M8x25	7	900333
19	Self lock nut M8	14	900027
20	No-stress support plate	1	001060
21	No-stress Plus	1	900555
22	Transmission shaft	1	B19003025
23	Key 18x8x60	1	900732
24	Solenoid support plate	1	001061
25	Solenoid	1	900487
26	Washer $\varnothing$ 5x10	8	900471
27	Screw TCEI M5x50	4	900571
28	Self lock nut M5	4	900702
29	Hinge	1	B19001009
30	Screen	1	B19001026
31	Spring	1	900434
32	Key 12x8x35	1	900664

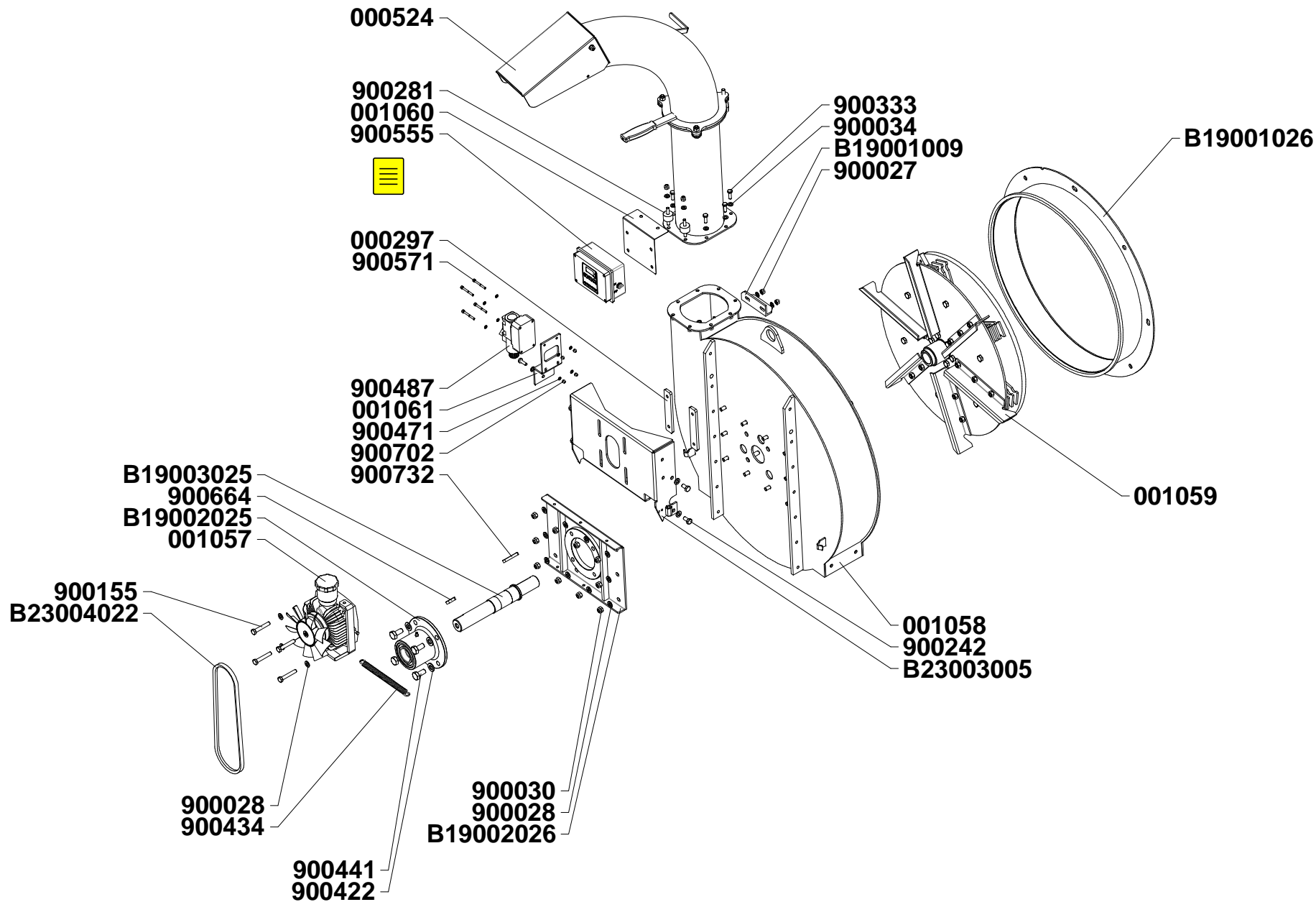

**Bio 235****TAB. 15 – Exhaust pipe**

Pos.	Description	No.	Code
1	Curve pipe	1	B19001015
2	Straight pipe	1	B19001008
3	Lock	3	B19001033
4	Screw TE M10x35	2	900442
5	Elastic washer $\varnothing$ 10	2	900315
6	High nut M10	2	900470
7	Knob 6E M10x30	1	900208
8	Hand grip M10 M	1	B19001034
9	Lever	1	B19001013
10	Output casing	1	B19001012
11	Screw TE M8x20	2	900378
12	Washer $\varnothing$ 8x16	2	900034
13	Self lock nut M8	2	900027
14	Washer $\varnothing$ 6x12	1	900365
15	Screw TE M6x16	1	900366
16	High nut M6	1	900733
17	Knob 25x8	1	900009

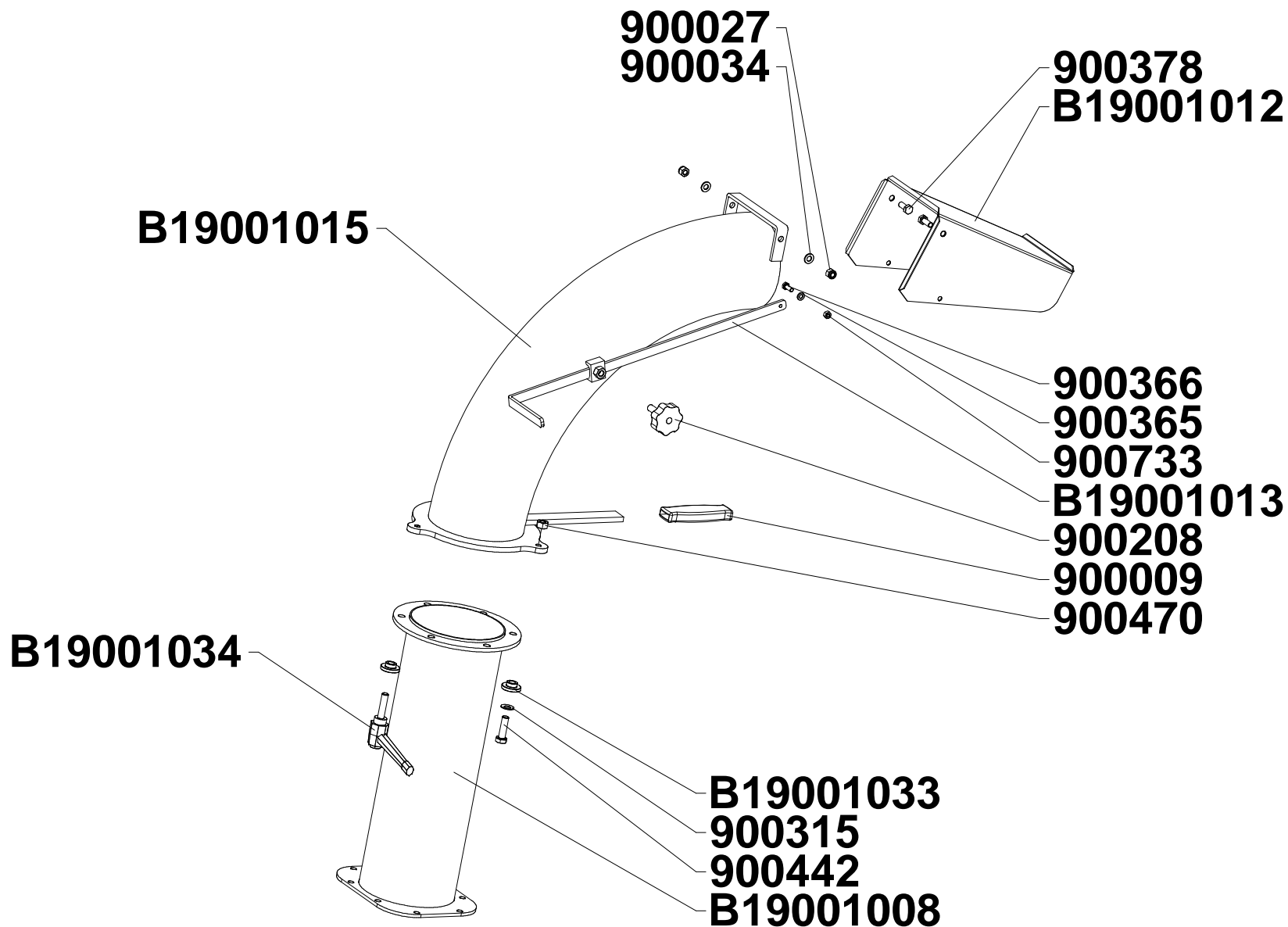

**Bio 235**

**TAB. 16 – Transmission flange (B/D)**



Pos.	Description	No.	Code
1	Transmission flange	1	B19002025
2	Spacer H=64	1	B19002023
3	Bearing 6209 2RS	2	900734
4	Greaser M8x1	1	900468

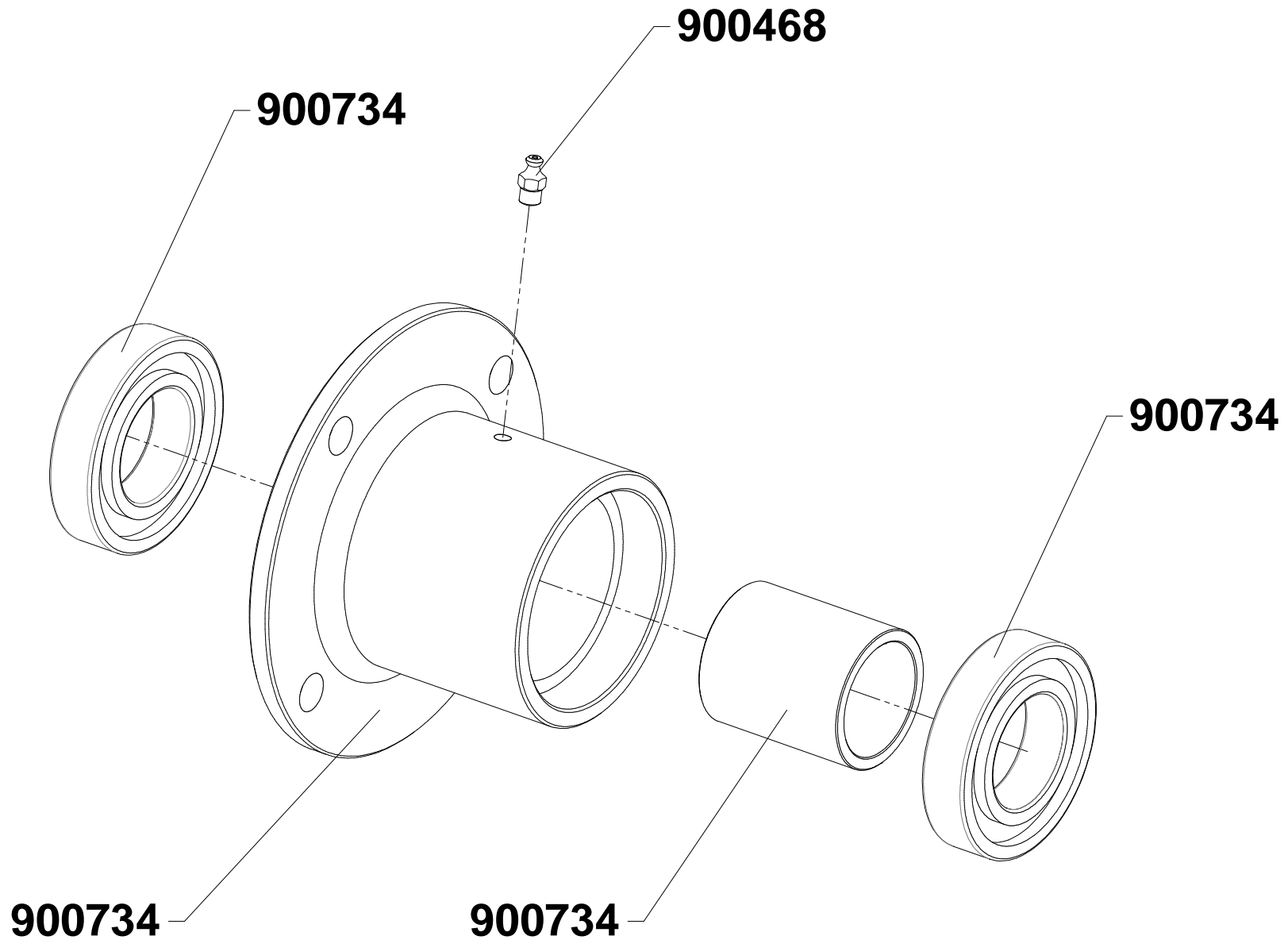

**Bio 235****TAB. 17 – Rotor Assembly (B/D)**

Pos.	Description	No.	Code
1	Chipper disk (front)	1	001004
2	Chipper disk (rear)	1	B19001018
3	Aluminium plug	1	B19001039
4	Reinforced hub	1	000789
5	Central chipper blade	1	B19001022
6	Side chipper blade	2	CP10010052
7	Screw TSPEI M10x20	8	500018810
8	Screw TSPEI M8x20	1	900510
9	Screw TE M12x30	14	900308
10	Rod	6	B19001019
11	Screw TE M10x20	18	900242
12	Paddle	6	B19001017
13	Screw TE M12x25	6	900450
14	Spacer H=12	12	B19001021
15	Spacer H=6	18	B19001020
16	Hammer 6 mm	24	B300T010016
17	Hub lock	1	000532

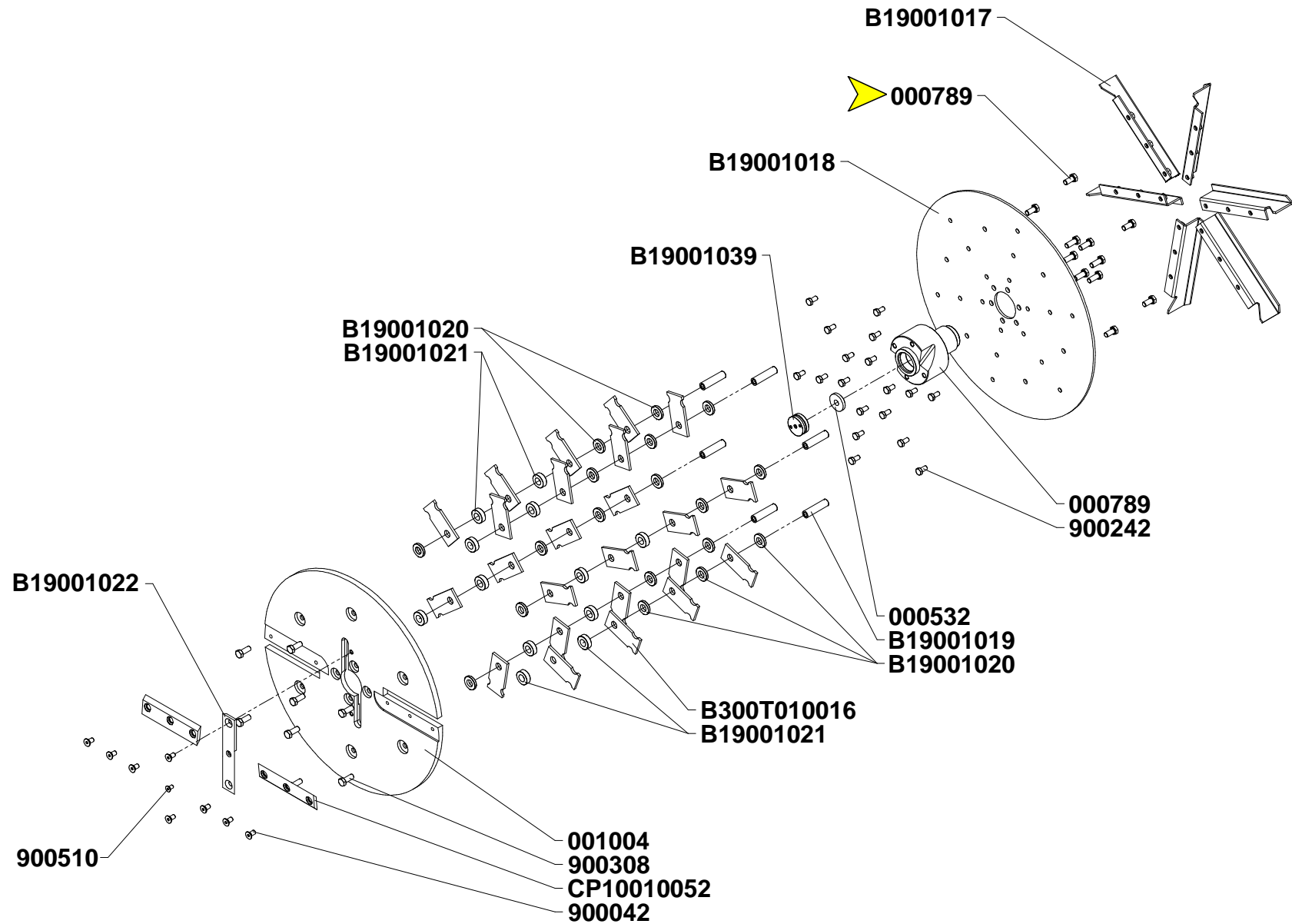

**Bio 235**

**TAB. 18 – Pump Assembly**



Pos.	Description	No.	Code
1	Oil tank	1	900075
2	Pump	1	900093
3	Spacer	1	000295
4	Pulley 1A 95	1	900735
5	Bush 1610 ø17	1	900736
6	Lever	1	B23003009
7	Washer ø10x20	1	900028
8	Self lock nut M10	1	900030
9	Pump fan	1	900255
10	Fan disk	1	000294
11	Screw UNF	1	900273

